

Think BIBLICALLY

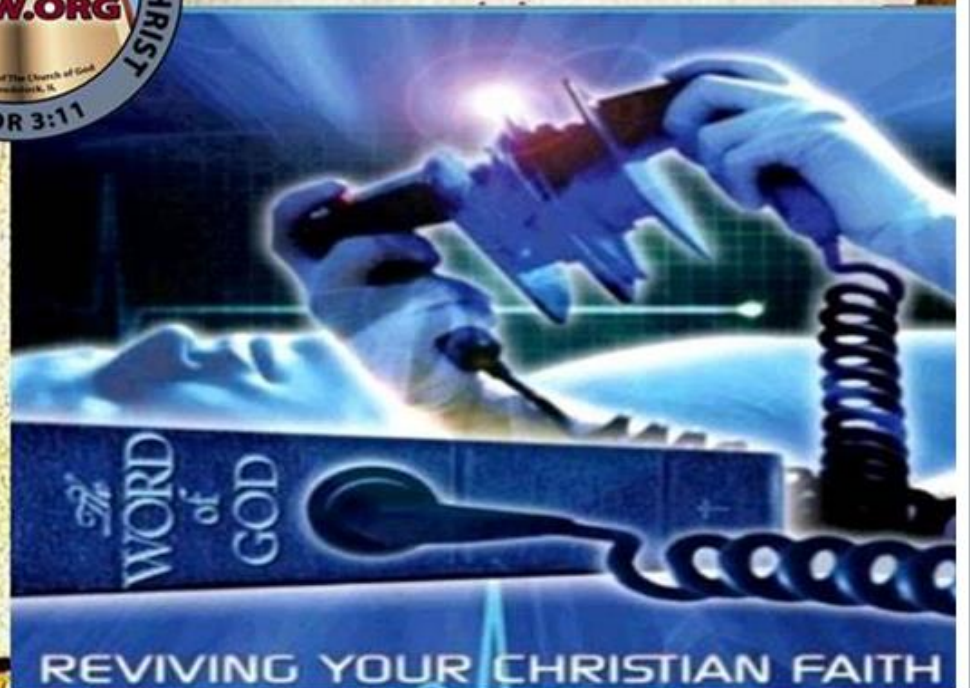

RENEW your mind ROMANS 12:12

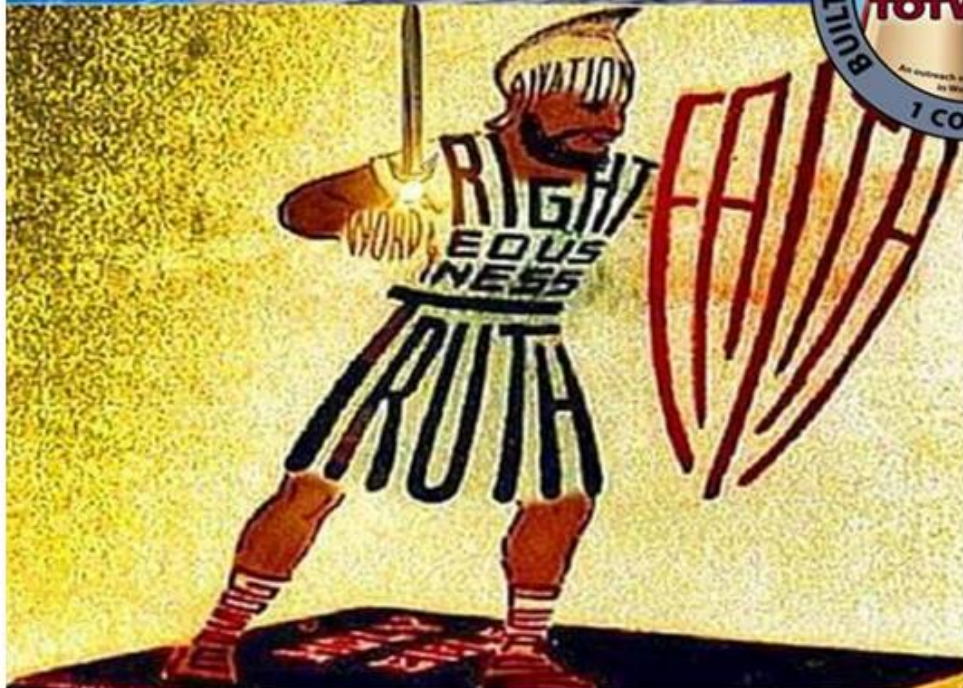
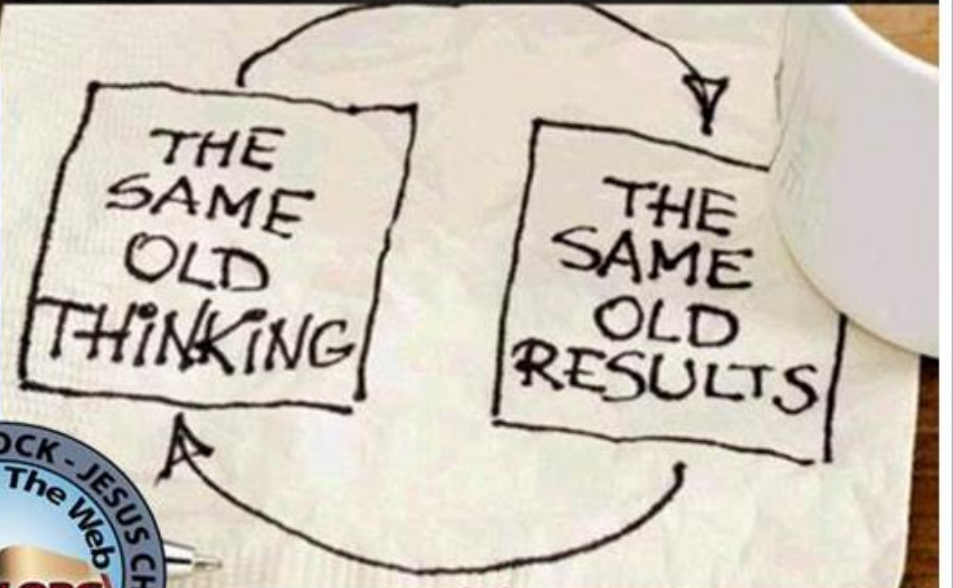

Dwelling Together

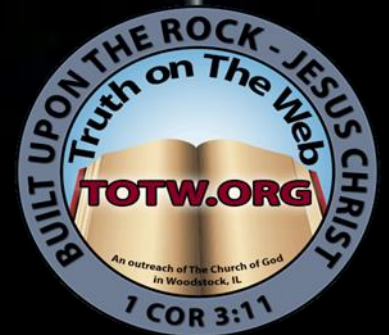

Matthew 19:3-4 The Pharisees also came unto Him, tempting Him, and saying unto Him, Is it lawful for a man to put away his wife for every cause? And He answered and said unto them, Have ye not read, that He which made *them* at the beginning made them male and female

Matthew 19:5-6 And said, For this cause shall a man leave father and mother, and shall cleave to his wife: and they twain shall be one flesh? Wherefore they are no more twain, but one flesh. What therefore God hath joined together, let not man put asunder.

Matthew 19:7-8 They say unto Him, Why did Moses then command to give a writing of divorcement, and to put her away? He saith unto them, Moses **because of the hardness of your hearts suffered you to put away your wives:** but from the beginning it was not so.

Why do marriages split?

- * Wrong Person / Too Young
- * Grew Apart / Fell Out Of Love
- * Arguments / Conflicts
- * Financial Strains
- * Lack Of Intimacy
- * Adultery



* Wrong Person / Too Young

* Grew Apart / Fell Out Of love

* Arguments / Conflicts

* Financial Strains

* Lack Of Intimacy

* Adultery

Ephesians 5:22-27 Wives, submit yourselves unto your own husbands, as unto the Lord. **23** For the husband is the head of the wife, even as Christ is the head of the church: and he is the saviour of the body. **24** Therefore as the church is subject unto Christ, so *let the wives be* to their own husbands in every thing. **25** Husbands, love your wives, even as Christ also loved the church, and gave Himself for it; **26** That He might sanctify and cleanse it with the washing of water by the word, **27** That He might present it to Himself a glorious church, not having spot, or wrinkle, or any such thing; but that it should be holy and without blemish.

Ephesians 5:28-33 So ought men to love their wives as their own bodies. He that loveth his wife loveth himself. **29** For no man ever yet hated his own flesh; but nourisheth and cherisheth it, even as the Lord the church: **30** For we are members of his body, of his flesh, and of his bones. **31** For this cause shall a man leave his father and mother, and shall be joined unto his wife, and they two shall be one flesh. **32** This is a great mystery: but I speak concerning Christ and the church. **33** Nevertheless let every one of you in particular so love his wife even as himself; and the wife see that she reverence *her* husband.

1 Corinthians 12:27 Now ye are the body of Christ, and members in particular.

Romans 12:5 So we, being many, are one body in Christ, and every one members one of another.

John 17:11 And now I am no more in the world, but these are in the world, and I come to Thee. Holy Father, keep through Thine own name those whom Thou hast given Me, **that they may be one, as We are.**

John 17:20-23 Neither pray I for these alone, but for them also which shall believe on Me through their word; **That they all may be one; as Thou, Father, art in Me, and I in Thee, that they also may be one in Us:** that the world may believe that Thou hast sent Me. And the glory which Thou gavest Me I have given them; **that they may be one, even as We are one: I in them, and Thou in Me, that they may be made perfect in one;** and that the world may know that Thou hast sent Me, and hast loved them, as Thou hast loved Me.

Why do churches split?

- * Doctrinal Differences
 - Calendar
 - Names

- * Personal Dislikes / Disagreements

- * Leadership / Submission Issues

Why should churches split?

1 Corinthians 12:27 Now ye are **the body of Christ**, and members in particular.

Romans 12:5 So we, being many, are **one body in Christ**, and every one members one of another.

Romans 16:17-18 Now I beg you, brothers, look out for those who are causing the divisions and occasions of stumbling, contrary to the doctrine which you learned, and turn away from them. For those who are such don't serve our Lord, Jesus Christ, but their own belly; and by their smooth and flattering speech, they deceive the hearts of the innocent.

**Is there doctrine that you treasure
more than unity?**

Proverbs 18:1-2 Through desire a man, having separated himself, seeketh *and* intermeddleth with all wisdom. A fool hath no delight in understanding, but that his heart may discover itself.

Proverbs 18:1-2 Whoever isolates himself seeks his own desire; he breaks out against all sound judgment. A fool takes no pleasure in understanding, but only in expressing his opinion.

Where do conflicts come from?

James 4:1-3 Where do wars and fightings among you come from? Don't they come from your pleasures that war in your members? You lust, and don't have. You kill, covet, and can't obtain. You fight and make war. You don't have, because you don't ask. You ask, and don't receive, because you ask with wrong motives, so that you may spend it for your pleasures.

James 3:13-16 Are there some wise and understanding men among you? Then your lives will be an example of the humility that is born of true wisdom. But if your heart is full of rivalry and bitter jealousy, then do not boast of your wisdom—don't deny the truth that you must recognise in your inmost heart. You may acquire a certain superficial wisdom, but it does not come from God—it comes from this world, from your own lower nature, even from the devil. For wherever you find jealousy and rivalry you also find disharmony and all other kinds of evil.

1 Corinthians 3:3-4 For ye are yet carnal: for whereas there is among you envying, and strife, and divisions, are ye not carnal, and walk as men? For while one saith, I am of Paul; and another, I am of Apollos; are ye not carnal?

1 Corinthians 1:10 Now I beseech you, brethren, by the name of our Lord Jesus Christ, that ye all speak the same thing, and that there be no divisions among you; but that ye be perfectly joined together in the same mind and in the same judgment.

THE GREAT

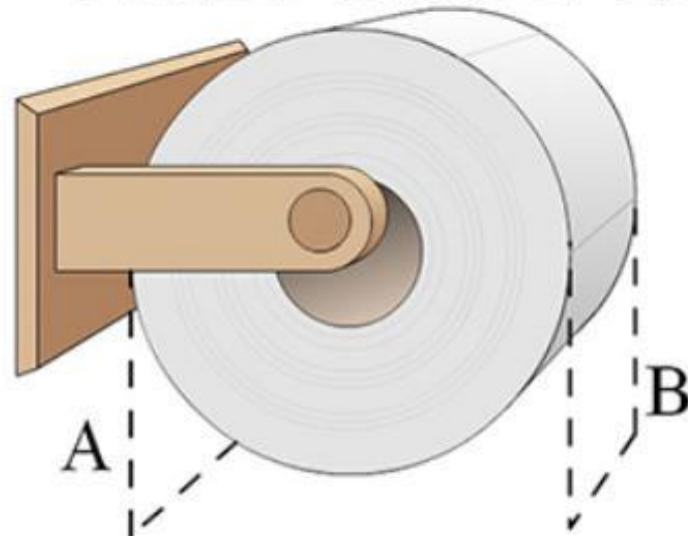

DEBATE

THE GREAT

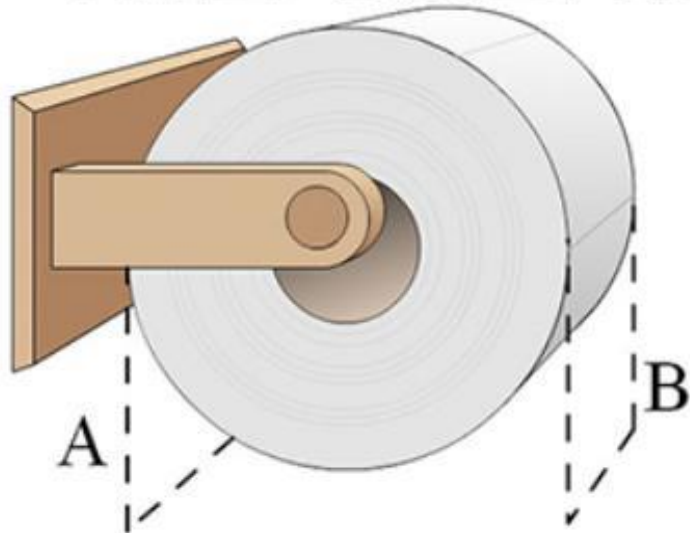

DEBATE

Disputable matters wherein the Scripture does not require adherence one way or the other. They do not apply to requirements of Law.

Judge Righteous Judgement

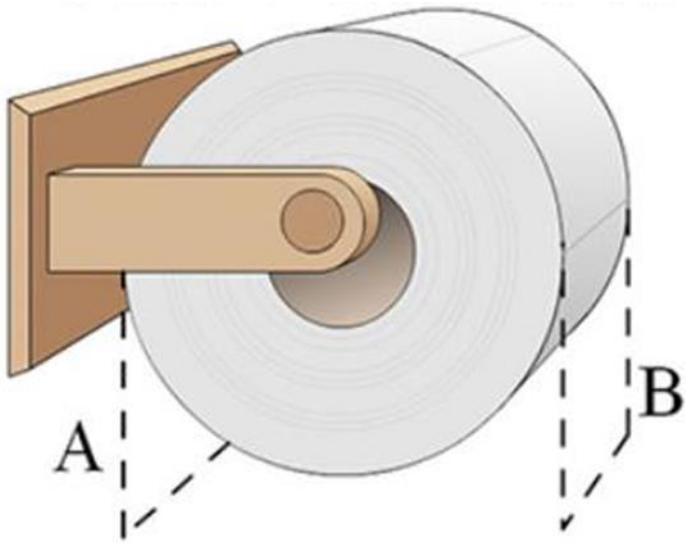

or

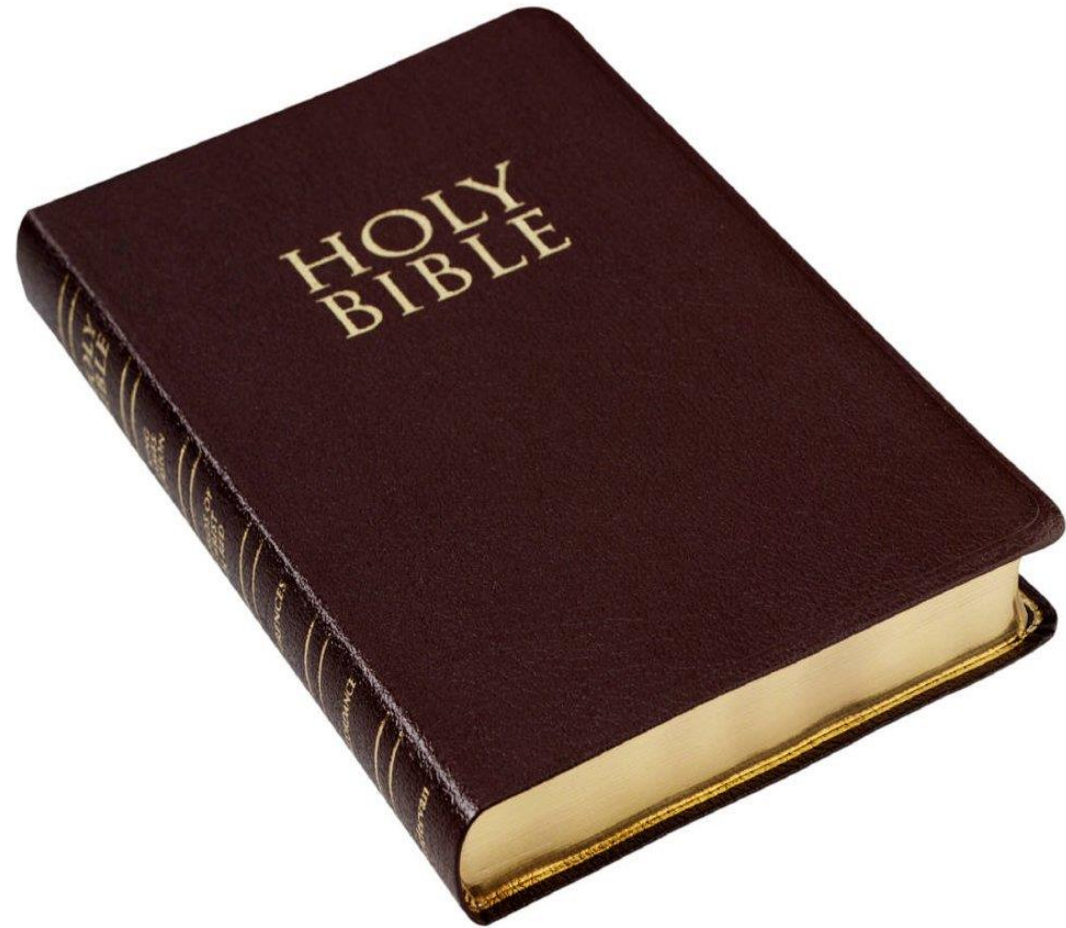

Romans 14:1-4 Him that is weak in the faith receive ye, but not to doubtful disputations. For one believeth that he may eat all things: another, who is weak, eateth herbs. Let not him that eateth despise him that eateth not; and let not him which eateth not judge him that eateth: for God hath received him. Who art thou that judgest another man's servant? to his own master he standeth or falleth. Yea, he shall be holden up: for God is able to make him stand.

Now receive one who is weak in faith, but not for disputes over opinions. WEB

Welcome the person who is weak in faith—but not in order to argue about differences of opinion. CEV

Accept the one whose faith is weak, without quarreling over disputable matters. NIV

Be willing to accept those who still have doubts about what believers can do. And don't argue with them about their different ideas. ERV

Romans 14:13-15 Let us not therefore judge one another any more: but judge this rather, that no man put a stumblingblock or an occasion to fall in his brother's way. I know, and am persuaded by the Lord Jesus, that there is nothing unclean of itself: but to him that esteemeth any thing to be unclean, to him it is unclean. But if thy brother be grieved with thy meat, now walkest thou not charitably. Destroy not him with thy meat, for whom Christ died.

Romans 14:19-23 Let us therefore follow after the things which make for peace, and things wherewith one may edify another. For meat destroy not the work of God. All things indeed are pure; but it is evil for that man who eateth with offence. It is good neither to eat flesh, nor to drink wine, nor any thing whereby thy brother stumbleth, or is offended, or is made weak. Hast thou faith? have it to thyself before God. Happy is he that condemneth not himself in that thing which he alloweth. And he that doubteth is damned if he eat, because he eateth not of faith: for whatsoever is not of faith is sin.

Romans 15:1-7 We then that are strong ought to bear the infirmities of the weak, and not to please ourselves. Let every one of us please his neighbour for his good to edification. For even Christ pleased not Himself; but, as it is written, The reproaches of them that reproached thee fell on me. For whatsoever things were written aforetime were written for our learning, that we through patience and comfort of the Scriptures might have hope. Now the God of patience and consolation grant you to be likeminded one toward another according to Christ Jesus: That ye may with one mind and one mouth glorify God, even the Father of our Lord Jesus Christ. Wherefore receive ye one another, as Christ also received us to the glory of God.

1 Corinthians 8:1-4 Now as touching things offered unto idols, we know that we all have knowledge. Knowledge puffeth up, but charity edifieth. And if any man think that he knoweth any thing, he knoweth nothing yet as he ought to know. But if any man love God, the same is known of him. As concerning therefore the eating of those things that are offered in sacrifice unto idols, we know that an idol is nothing in the world, and that there is none other God but one.

1 Corinthians 8:9-11 But take heed lest by any means this liberty of yours become a stumblingblock to them that are weak. For if any man see thee which hast knowledge sit at meat in the idol's temple, shall not the conscience of him which is weak be emboldened to eat those things which are offered to idols; And through thy knowledge shall the weak brother perish, for whom Christ died?

1 Corinthians 8:12-13 But when ye sin so against the brethren, and wound their weak conscience, ye sin against Christ. Wherefore, if meat make my brother to offend, I will eat no flesh while the world standeth, lest I make my brother to offend.



**NO
PETS
ALLOWED**

1 Corinthians 9:19-23 For though I be free from all *men*, yet have I made myself servant unto all, that I might gain the more. And unto the Jews I became as a Jew, that I might gain the Jews; to them that are under the law, as under the law, that I might gain them that are under the law; To them that are without law, as without law, (being not without law to God, but under the law to Christ,) that I might gain them that are without law. To the weak became I as weak, that I might gain the weak: I am made all things to all *men*, that I might by all means save some. And this I do for the gospel's sake, that I might be partaker thereof with *you*.

1 Corinthians 10:31-33 Whether therefore ye eat, or drink, or whatsoever ye do, do all to the glory of God. Give none offence, neither to the Jews, nor to the Gentiles, nor to the church of God: Even as I please all men in all things, not seeking mine own profit, but the profit of many, that they may be saved.

1) Having the “right” to do something does not mean we are free to do it in every circumstance, regardless of its effects on others.

2) The believer’s liberty in Christ can and should be voluntarily limited in order not to cause a weaker brother to sin by violating his conscience. Liberty is limited in love.

3) Maintaining the unity of the Spirit in the bond of love may require a believer to give up his personal “right” to a thing.

4) We should avoid anything that would make a weak brother think less of his faith or that would make an unsaved person feel more at ease in his sin.

Philippians 3:15-16 Let us therefore, as many as are perfect, think this way. If in anything you think otherwise, God will also reveal that to you. Nevertheless, to the extent that we have already attained, let us walk by the same rule. Let us be of the same mind.

Philippians 2:1-7 *If there be* therefore any consolation in Christ, if any comfort of love, if any fellowship of the Spirit, if any bowels and mercies, Fulfil ye my joy, that ye be likeminded, having the same love, *being* of one accord, of one mind. *Let nothing be done* through strife or vainglory; but in lowliness of mind let each esteem other better than themselves. Look not every man on his own things, but every man also on the things of others. Let this mind be in you, which was also in Christ Jesus: Who, being in the form of God, thought it not robbery to be equal with God: But made himself of no reputation, and took upon him the form of a servant, and was made in the likeness of men:

Ephesians 4:1-3 I therefore, the prisoner of the Lord, beseech you that ye walk worthy of the vocation wherewith ye are called, With all lowliness and meekness, with longsuffering, forbearing one another in love; Endeavouring to keep the unity of the Spirit in the bond of peace.

Ephesians 4:11-16 He gave some to be apostles; and some, prophets; and some, evangelists; and some, shepherds and teachers; for the perfecting of the saints, to the work of serving, to the building up of the body of Christ; until we all attain to the unity of the faith, and of the knowledge of the Son of God, to a full grown man, to the measure of the stature of the fullness of Christ; that we may no longer be children, tossed back and forth and carried about with every wind of doctrine, by the trickery of men, in craftiness, after the wiles of error; but speaking truth in love, we may grow up in all things into him, who is the head, Christ; from whom all the body, being fitted and knit together through that which every joint supplies, according to the working in measure of each individual part, makes the body increase to the building up of itself in love.

Mark 10:9 What therefore God hath joined together, let not man put asunder.

Think BIBLICALLY

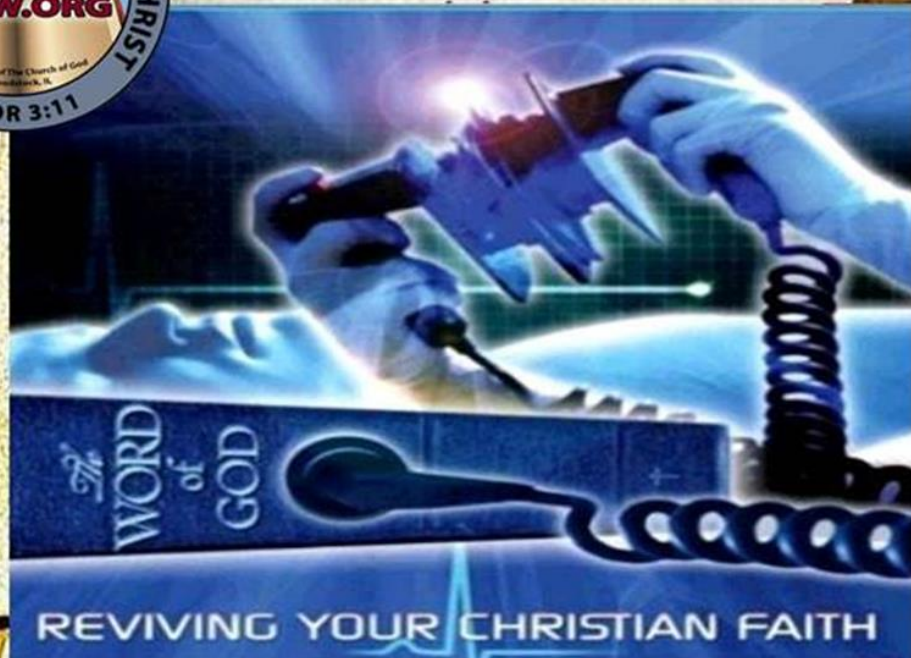
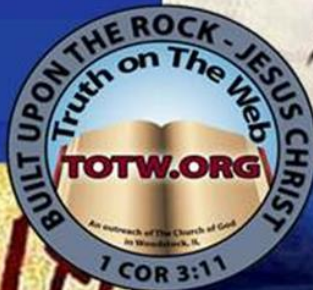
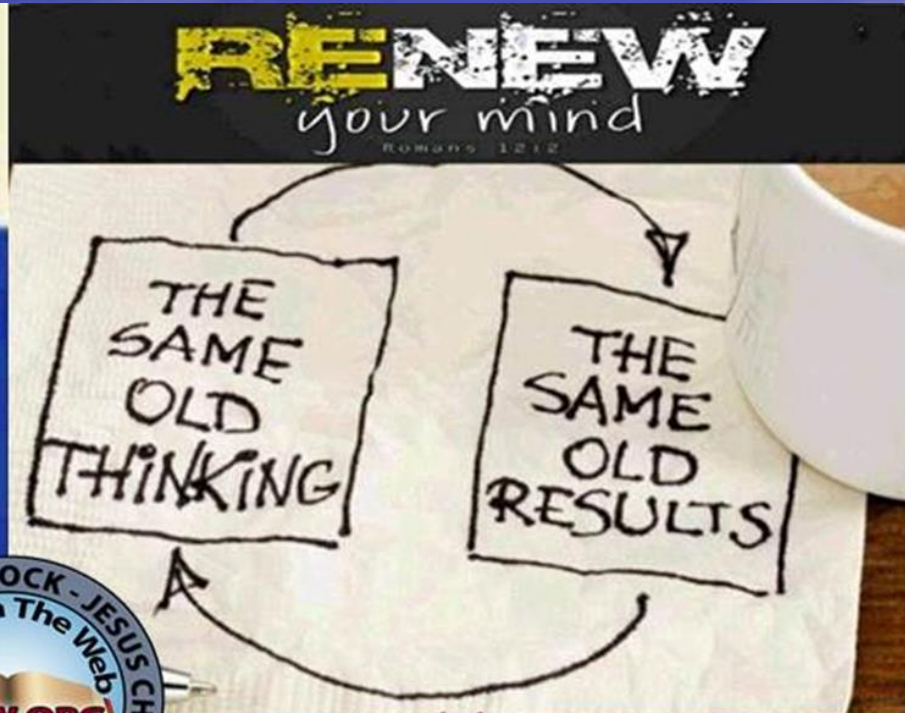

www.totw.org